

# Component Interfaces

## Introduction

**Component Interfaces** are a way to define assembly constraints in the part model *before* assembling the component into the assembly. With properly defined **Component Interfaces**, parts can be *automatically* assembled into the assembly.

## Defining an Interface

In the part model, select **Edit, Setup, Comp Interface**. The **Interface Definition** dialog box is used to create 'interfaces' in the part. An interface is a set of assembly constraints defined in the part. A part can have multiple interfaces defined, one for each assembly in which the part is used. The **Interface Definition** dialog box is shown below.

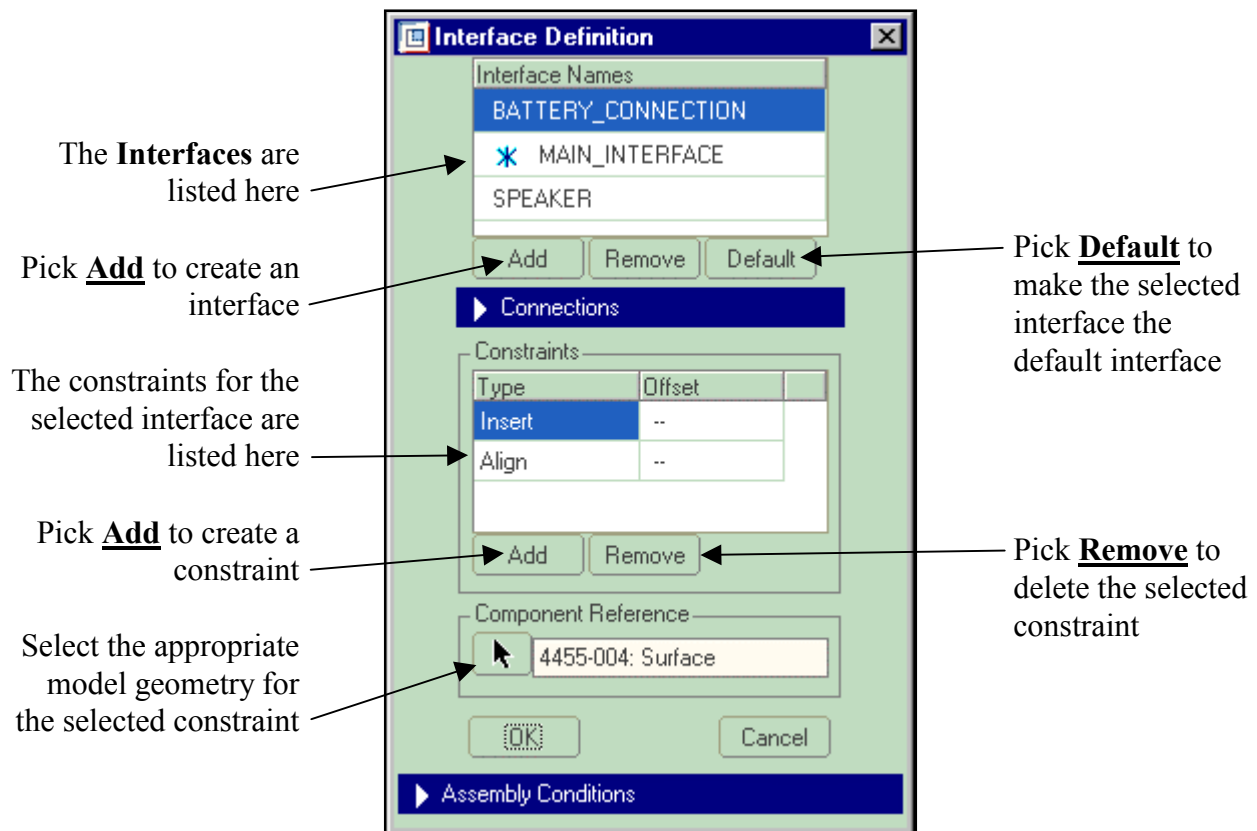

### Defining an Interface (continued)

Another method for defining **Component Interfaces** is to use the **Component Placement** dialog box. After manually adding assembly constraints for a particular component, pick as shown below to automatically create a **Component Interface** in that part.

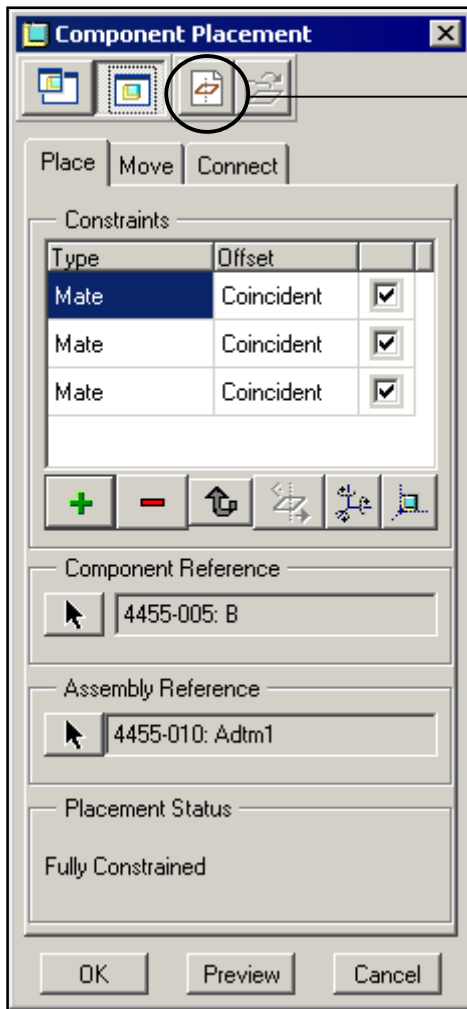

Pick here to access the **Select Interface** dialog box, to create a new interface in the part

Enter a name for the new interface here

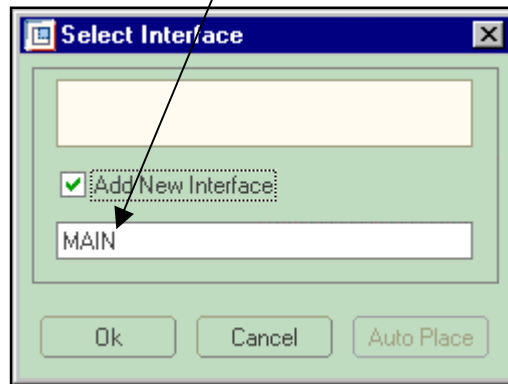

## Using an Interface

When assembling a component into the assembly, the system checks to see if the component has **Component Interfaces** defined. If the component has interfaces defined, the system presents the **Select Interface** dialog box. Select the interface you want to use, then pick **Auto Place**. The **Select Interface** dialog box is shown below.

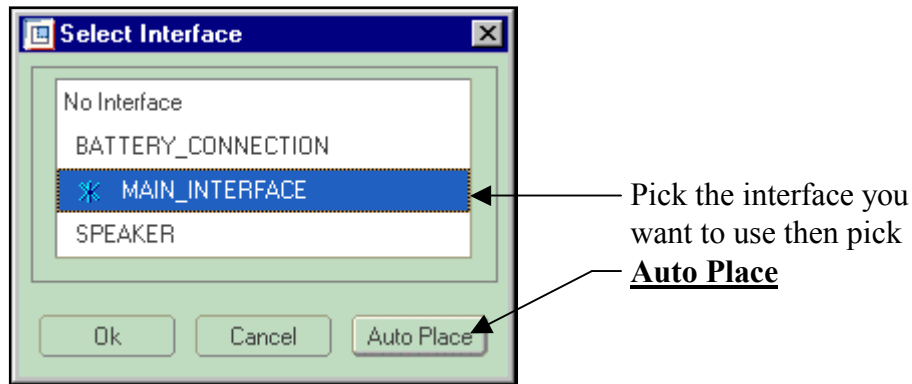

After selecting **Auto Place**, the system presents the **Auto Place Settings** dialog box, shown below. Select a location in the assembly where you want the component to be placed. The system will locate possible assembly references in the vicinity of the selected location. Pick **Apply** to accept the selected assembly constraints, then pick **OK** to complete the component placement.

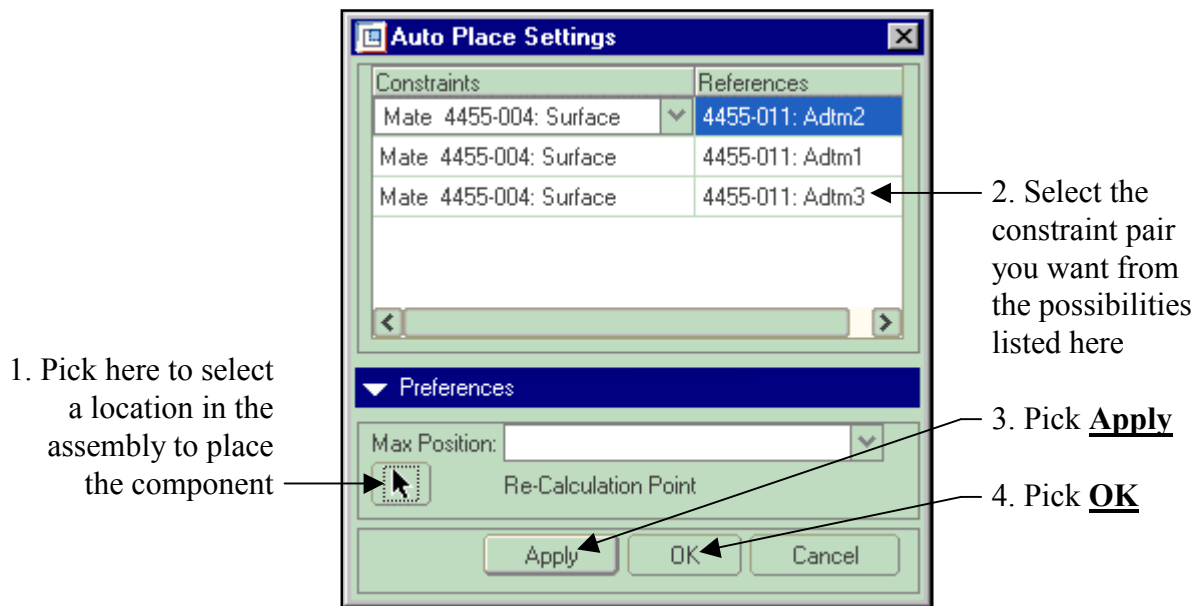

### Using an Interface (continued)

The **Component Placement** dialog box has a new icon at the top, which is used to display the **Component Interfaces** for the part being assembled. This allows you to change the interface used for a particular component when redefining that component in the assembly.

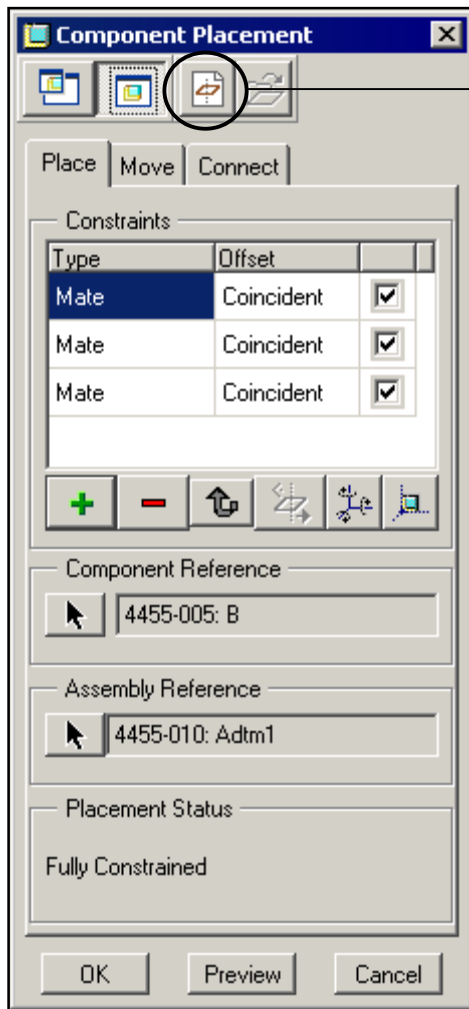

Pick here to access the **Select Interface** dialog box, to change the interface being used

Select the new interface here

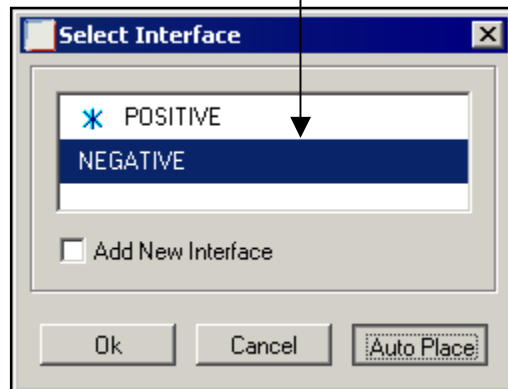

## *Component Interface Preferences*

Pick **Tools, Assembly Settings, Placement Preferences** to access the dialog box shown below. Use this dialog box to set **Component Interface** preferences.

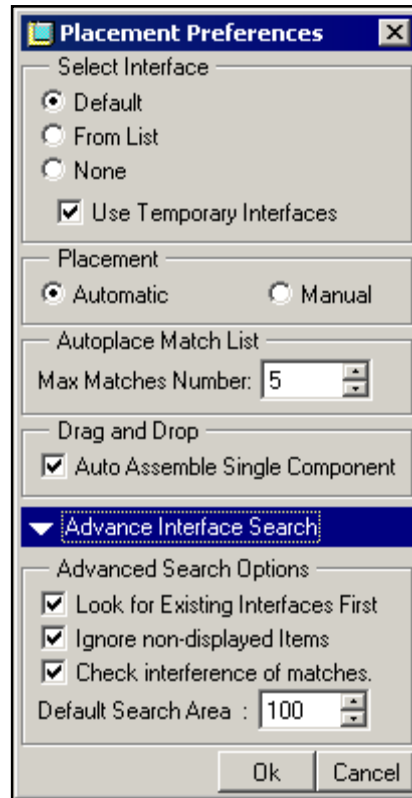

## *Component Interface Configuration Options*

The following config.pro options apply to **Component Interfaces**.

autoplace_single_comp	yes, no
create_temp_interfaces	no, yes

## Drag-and-Drop Component Placement

Components can be automatically assembled into the assembly using a ‘drag-and-drop’ technique. The component must have at least one **Component Interface** defined. In the assembly, set the **Selection Preferences** to **Geometry**. Pick the references in the assembly, using the CTRL key to select multiple entities. Next open the **Folder Browser** (or the **Personal Favorites**), select the desired component and *drag* it into the graphics area as shown below. The component is *automatically* placed into the assembly using the default interface in the component and the pre-selected geometric references in the assembly.

If a component is dropped onto the **Model Tree** of an assembly, it is added to the assembly as an ‘unplaced’ component.

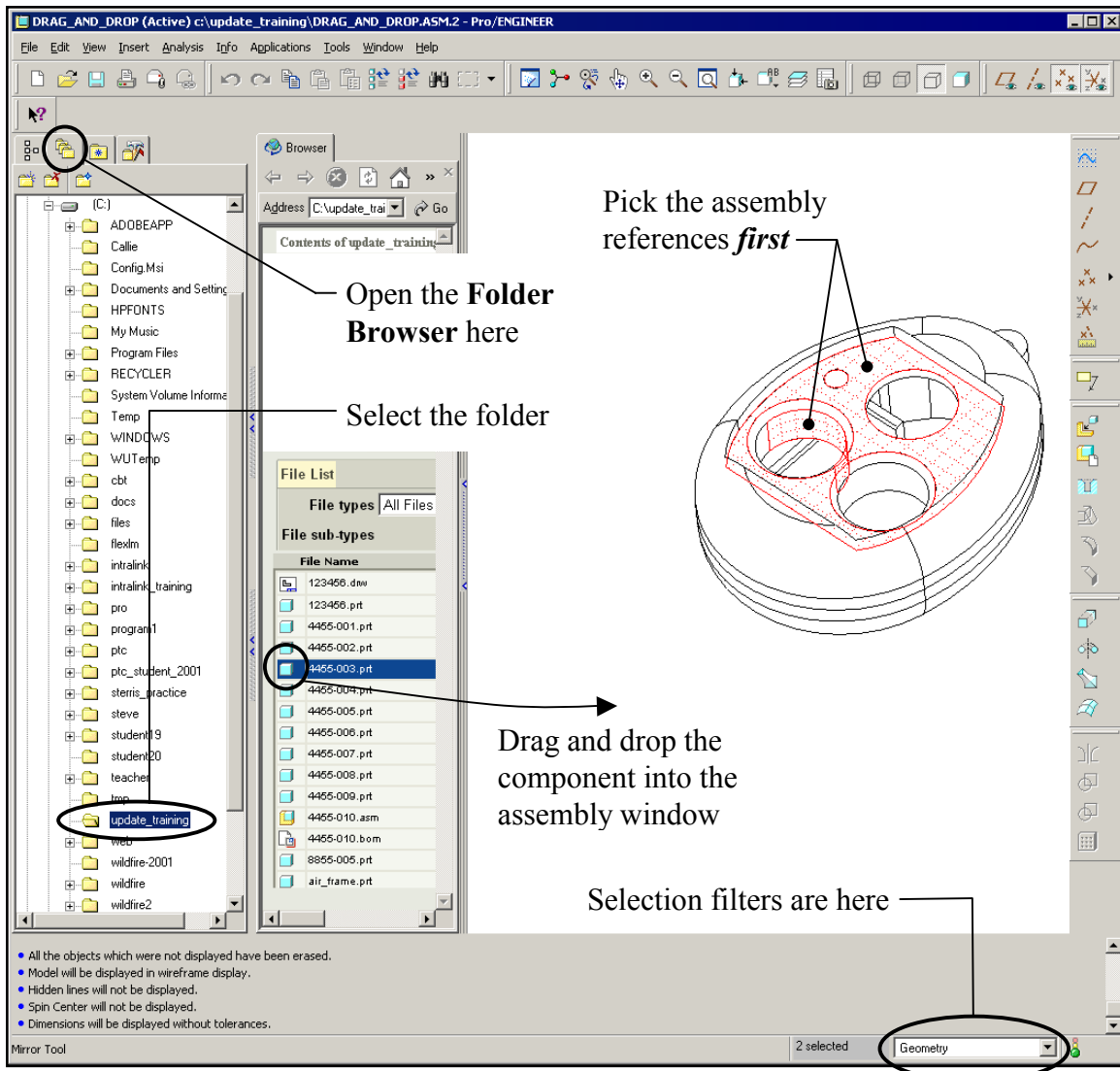



## EXERCISE 12 - COMPONENT INTERFACES

### Task 1: Create an interface in a part.

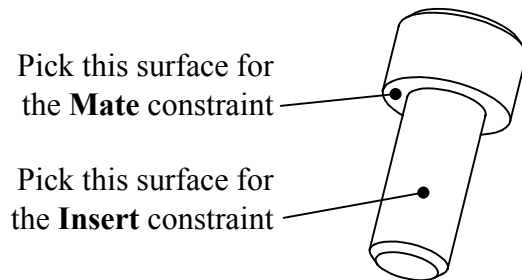
- **Open** the generic part called 'skt\_hd\_cap\_in.prt' 
- Pick **Edit, Setup, Comp Interface**
- Pick the part as shown below for the first (Mate) constraint





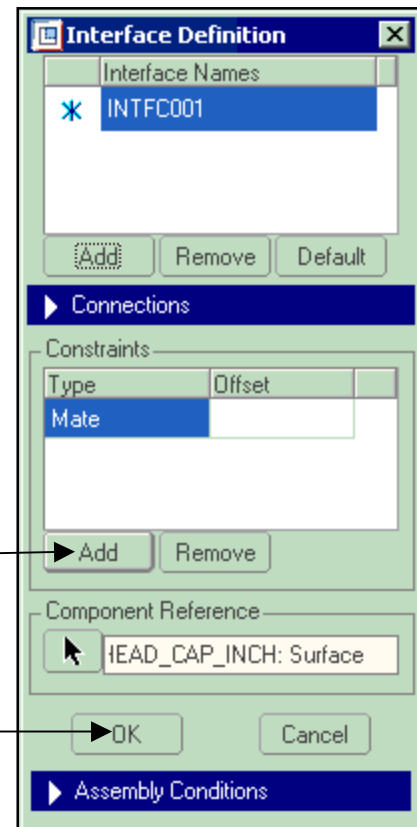

- Pick **Add** here 
- Change the second constraint to **Insert**
- Pick the shaft of the bolt as shown above
- Pick **OK** here 
- Pick **Done**
- **Save** the part and **Close** the window 

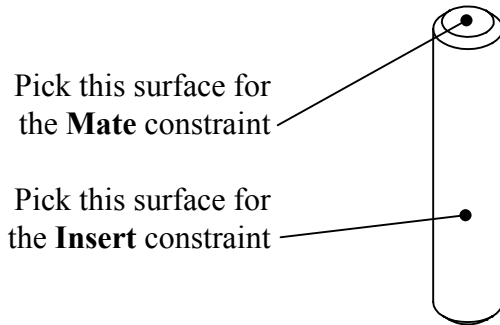

**Task 2: Create an interface in a part.**

- **Open** the part called ‘dowel\_pin\_inch.prt’ 
- Open the *Generic* model
- Pick **Edit, Setup, Comp Interface**
- Pick the part as shown below for the first (Mate) constraint



- Pick **Add** here 
- Change the second constraint to **Insert**
- Pick the cylindrical surface as shown above
- Pick **OK** here 
- Pick **Done**
- **Save** the part and **Close** the window 

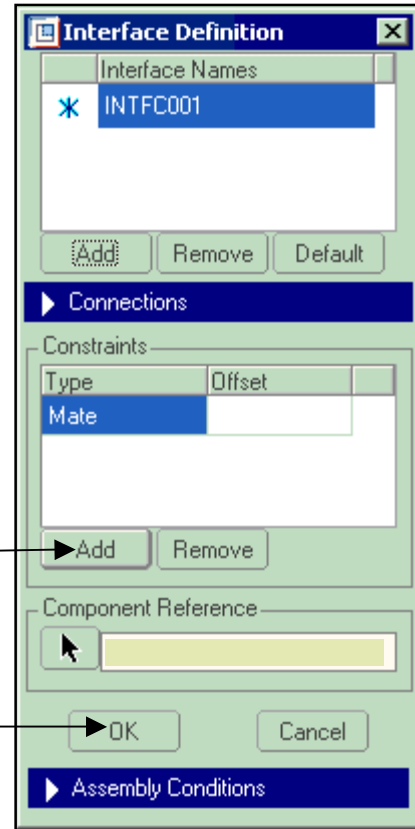



---

**Task 3: Create an interface in a part.**

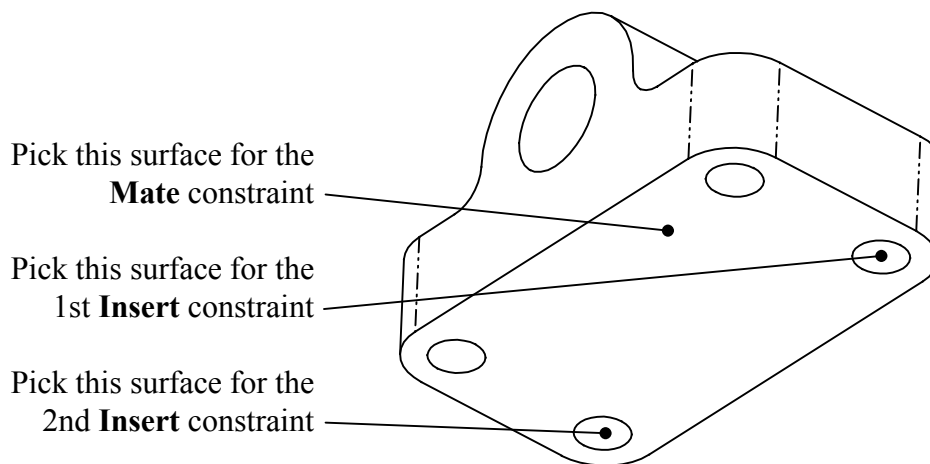

---

- **Open** the part called 'bearing\_block.prt' 
- Pick **Edit, Setup, Comp Interface**
- Pick the bottom surface of the part as shown below for the first (Mate) constraint
- Pick **Add** to add a second constraint
- Change the second constraint to **Insert**
- Pick the cylindrical surface as shown below
- Pick **Add** to add a third constraint
- Change the third constraint to **Insert**
- Pick the cylindrical surface as shown below



- Pick **OK** in the **Interface Definition** dialog box
- Pick **Done**
- **Save** the part and **Close** the window 

**Task 4: Assemble parts with component interfaces.**

- Create a new assembly called 'lab12' using **File, New** 
- Pick **Tools, Assembly Settings, Placement Preferences**

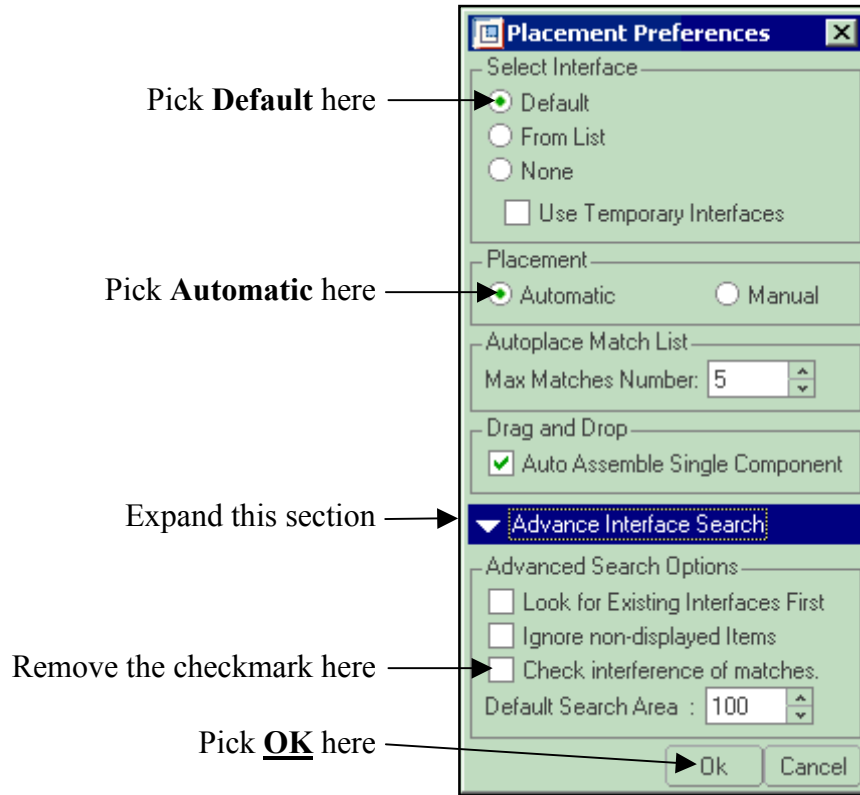

- Pick the **Component Assemble** icon  then pick the part called 'lab-12-plate-1' then pick **Open**, use the **Default** constraint then pick **OK**
- Click the left mouse button in an empty area of the graphics window
- Pick the **Component Assemble** icon again, then pick the part called 'bearing-block' then pick **Open**
- Pick exactly here

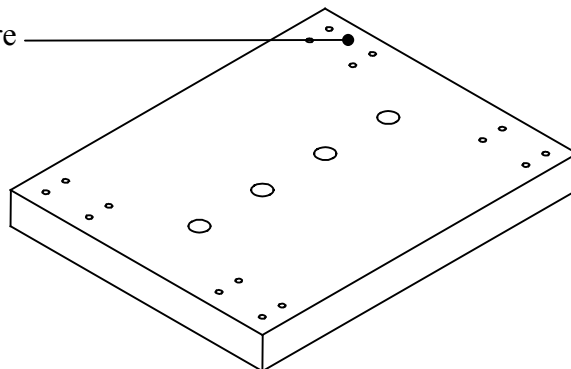

- Pick **Apply** in the **Auto Place Settings** dialog box
- Pick exactly here

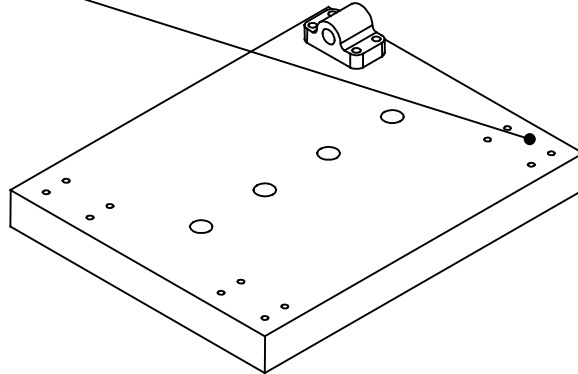

- Pick **Apply** in the **Auto Place Settings** dialog box
- Pick exactly here

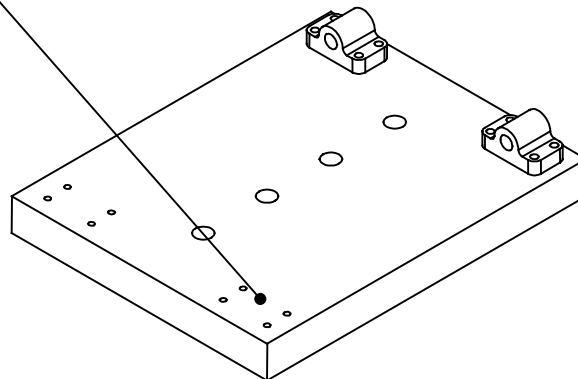

- Pick **Apply** in the **Auto Place Settings** dialog box
- Place the last bearing block in the appropriate location then pick **OK**
- The result is shown below
- **Save** the assembly 

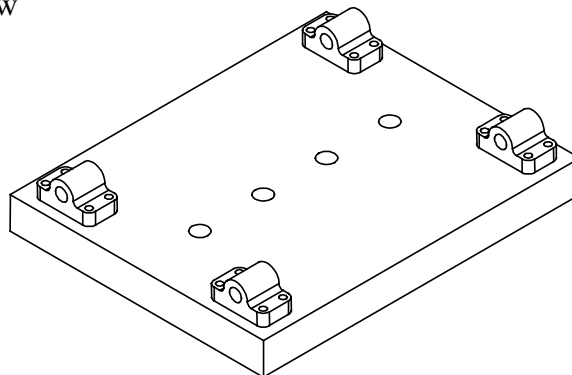

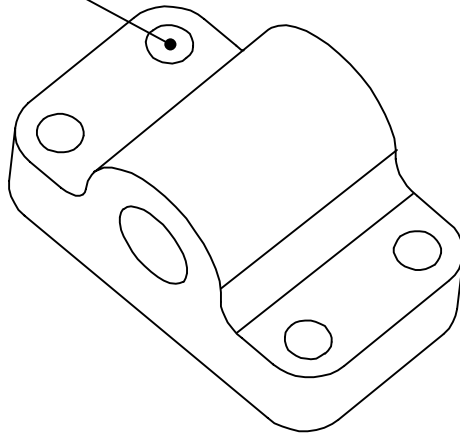

- Click the left mouse button in an empty area of the graphics window
- Zoom in on one of the bearing blocks as shown below
- Pick the **Component Assemble** icon 
- Pick the part called 'skt\_hd\_cap\_in' then pick **Open**
- Pick the instance called '5-21000-8' then pick **Open**
- Pick exactly here



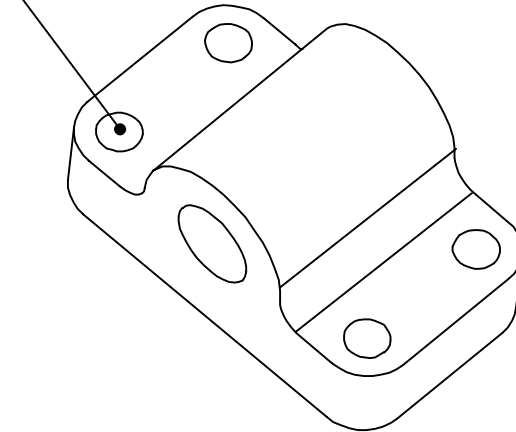

- Pick **Apply** in the **Auto Place Settings** dialog box
- Pick exactly here



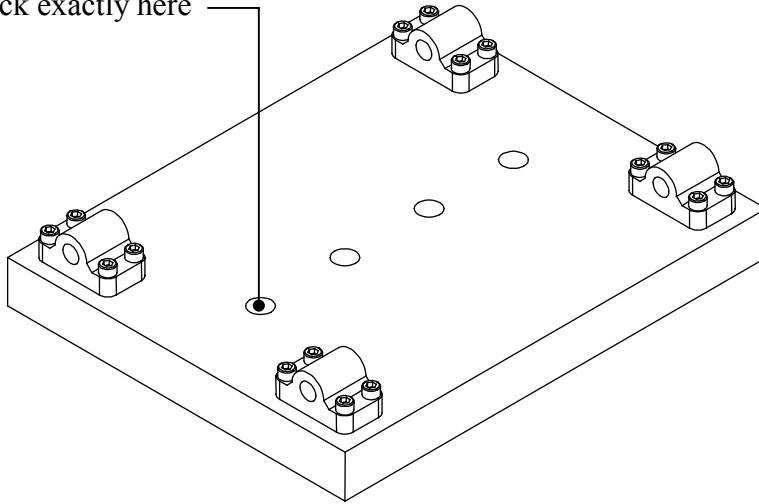

- Pick **Apply** in the **Auto Place Settings** dialog box
- Continue to place all 16 screws into the assembly then pick **OK**
- **Save** the assembly 

- Click the left mouse button in an empty area of the graphics window
- Pick the **Component Assemble** icon 
- Pick the part called 'dowel\_pin\_inch' then pick **Open**
- Pick the instance called 'dowel\_pin\_inch\_11' then pick **Open**
- Pick exactly here 

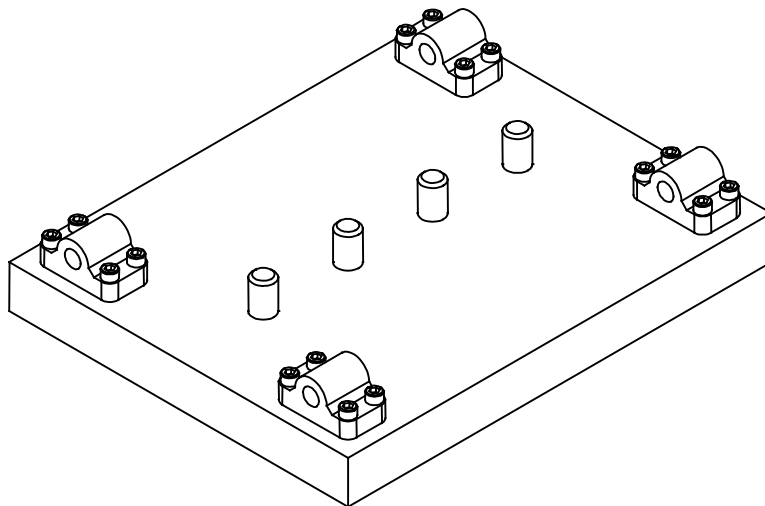

- Pick **OK**
- Pattern the dowel pin using a reference pattern
- The result is shown below
- **Save** the assembly 

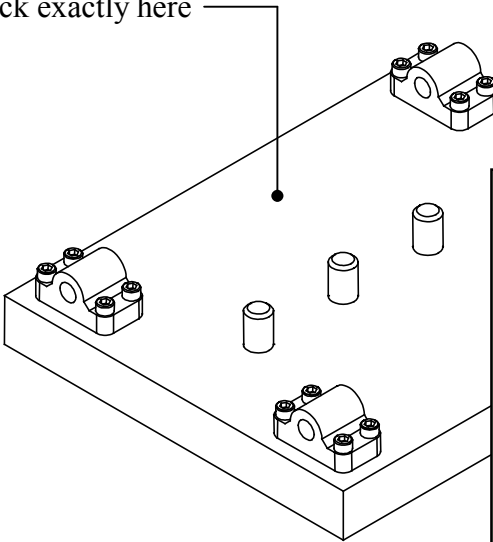

- Click the left mouse button in an empty area of the graphics window
- Pick the **Component Assemble** icon 
- Pick the part called 'slide\_post' then pick **Open**
- Pick exactly here 

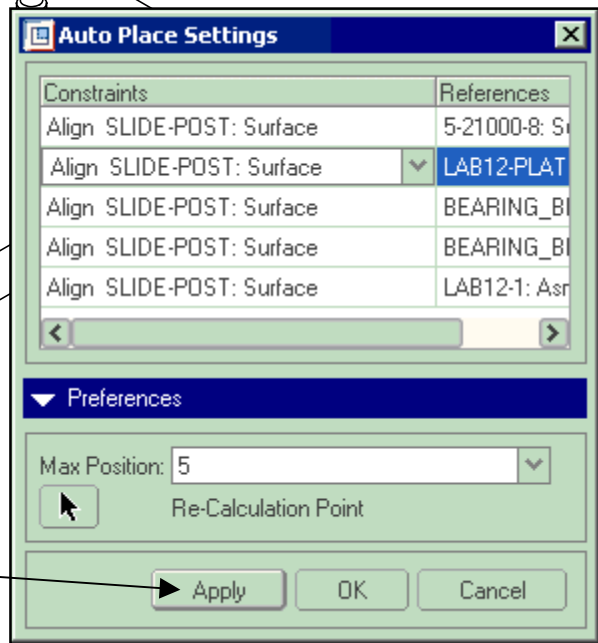

- In the **Auto Place Settings** dialog box, select the appropriate constraint that matches the figure shown below then pick **Apply**
- Place the other slide post as shown below then pick **OK**
- **Save** the assembly and **Close** the window 

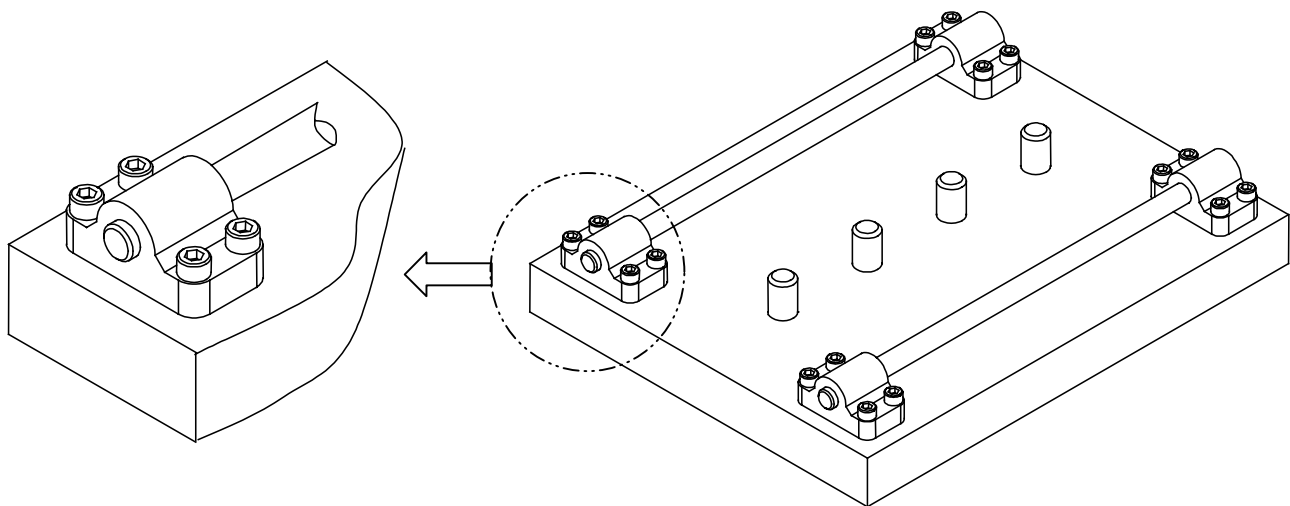

### Task 5: Assemble components using 'drag-and-drop'.

- **Open** the assembly called 'drag\_and\_drop.asm' 
- Open the **Folder Browser** and the browser as shown below
- Set the selection filter to **Geometry**, then pick the two part surfaces as shown below
- Select the appropriate folder for your system
- Drag the part called 4455-003 into the assembly window
- Repeat for the other battery
- **Save** the assembly and **Close** the window 